

APPLICATION NOTE

REMOTE DISPLAY SOLUTION FOR 2-WIRE FAMILY

Revision Record:

Date	Description	Written by	Rev.
10/6/2007	1 st release	Itay Weichselbaum	1.00

This document contains proprietary information that is the sole property of **Solid Applied Technologies Ltd.** The document is submitted to the recipient for his use only. By receiving this document; the recipient undertakes not to duplicate or to disclose, in part or the whole, any of the information contained herein; to any third party; without a-priori written permission from **Solid Applied Technologies Ltd.**

1.	SCOPE	3
2.	OBJECTIVES	3
3.	SOLID AT DEVICE OPERATION USING A REMOTE DISPLAY	3
4.	ABB C50 REMOTE DISPLAY	5
4.1	ABB C50 Remote Display specifications	5
4.2	ABB C50 description	6
4.3	Electrical Connections	6
5.	ABB C150/0110STD REMOTE DISPLAY	7
5.1	ABB C150 Remote Display specifications	7
5.2	ABB C150 description	8
5.3	Electrical Connections	9
6.	ABB 695FI REMOTE DISPLAY	9
6.1	ABB 695FI Remote Display specifications	9
6.2	ABB 695FI description	10
6.3	Electrical Connections	10
7.	SHIMADEN SD16	11
7.1	Shimaden Remote Display specifications	11
7.2	Shimaden SD16 description	12
7.3	Electrical Connections	12

1. SCOPE

Solid AT's 2-wire devices are suitable for tough and corrosive environments. Until now the Solid AT 2-wire devices had to be monitored locally. The new remote display solutions provide the user with the ability to monitor a 2-wire device from a distance and thereby let the user enjoy the benefits of cost effective 2-wire remote display solutions.

This document provides an introduction to four remote display solutions for 2-wire devices over a 4-20mA current loop by a third party.

2. OBJECTIVES

- Familiarize the user with the ABB C50 remote display solution.
- Familiarize the user with the ABB C150 remote display solution.
- Familiarize the user with the ABB 695FI remote display solution.
- Familiarize the user with the Shimaden SD16 remote display solution.

3. SOLID AT DEVICE OPERATION USING A REMOTE DISPLAY

The advantage of a remote display is often necessary for plants that don't have a PLC or a controller to monitor measurements. In order to observe the measurement value on the gauge's display, the user needs to climb on the vessel. Often the vessel is located far away from the control room.

Continuous measurement is often required in order to follow the process, maintain a fluent storage data base and/or to monitor process failures. Remote display gives the user an efficient solution to observe the measurement on the remote display device while using the 4-20mA current loop.

A remote display module enables the user to upgrade a 2-wire mono block device to a 'two-part system device'. Although the 2-wire device cannot be programmed by the remote display it can be installed far from the device it self for monitoring purposes (4-20mA protocol specification/HART/MODBUS RTU). The remote display enables operation of pumps and other auxiliary equipment while

using internal relays (if specific model supports relay operation).

Communication protocols are necessary to make a communication network more efficient. Using remote display with integrated Hart\MODBUS protocol enables the user to implement multi drop connection while establishing a wide range network over computer\PLC systems.

Also, connecting a remote display to a 4-wire device like **SmartScan**[®], will give the user the ability to monitor the process from two different locations while enjoying both the benefits of the **SmartScan**[®] and the remote display.

 **Note:**

Remote Display's input can be connected only to Solid AT device's 4-20mA current loop or 4-20mA output (4 wire device).

4. ABB C50 REMOTE DISPLAY

Solid AT has tested the ABB C50KK211000 remote display and found it to be the ideal solution for users that need the ability to monitor auxiliary equipment using a relay.

4.1 ABB C50 REMOTE DISPLAY SPECIFICATIONS

Operation

- **Display**
High intensity, 7-segment, 2 x 4 red LED display
Size upper 10mm (0.39 in.)
Lower 8mm (0.31 in.)
- **Configuration**
User defined via front panel and internal links.

Outputs

- **Primary output (fitted as standard)**
User configurable as either:
Relay:
SPDT 2A 120/240V AC
- **Output functions**
User configurable as either:
On/Off control output
Time proportioning PID control output

Analog Inputs

Single universal process input.

- **Type**
Universally Configurable for:
Thermocouple (THC)
Resistance Thermometer (RTD)
Linear Millivolt
Linear Current
Linear DC voltage
- **Input Sampling Rate**
1 sample/250ms
- **Input impedance:**
Millivolts/THC/RTD >100M Ω
Volts >47K Ω
Current <4.7 Ω

Physical

- **Size**
48mm (1.89 in.) x 48mm (1.89 in.)
x 110mm (4.33 in.) (Depth behind panel)
- **Weight**
<200g (0.44lbs.) approx.

Electrical

- **Voltage:**
90 to 264 V AC 50/60 Hz
- **Power consumption:**
<4VA

4.2 ABB C50 DESCRIPTION

The C50 Controller/Alarm unit is a compact single loop controller with the capability to measure, indicate and control a variety of process variables. The unit is ideal for simple PID control, offering On/Off or time proportioning control with a one shot self-tune facility. The unit is quickly set up for most process signal inputs and, with IP65 (NEMA3) front panel protection, is suitable for a wide range of applications.



4.3 ELECTRICAL CONNECTIONS

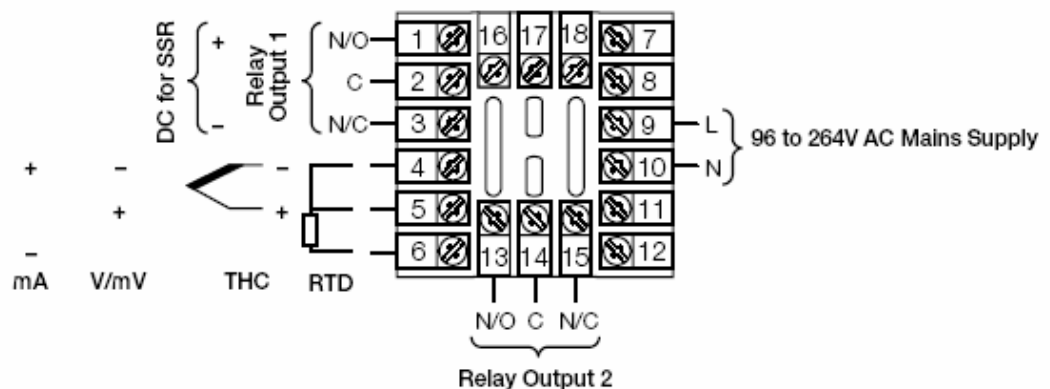

5. ABB C150/0110STD REMOTE DISPLAY

Solid AT has tested the ABB C150/0110STD remote display and found it to be the ideal solution for installations where a 24VDC power supply is required. Also having a MODBUS RTU RS485 communication protocol the remote display provides the user with the ability to connect the 2-wire device to a PLC MODBUS chain.

5.1 ABB C150 REMOTE DISPLAY SPECIFICATIONS

Operation

- **Display**
High intensity, 7-segment, 1 x 6 red LED display
Size 14mm (0.56 in.).
- **Configuration**
User defined via front panel and internal links.

Outputs

- **Primary output (fitted as standard)**
User configurable as either:
Relay:
SPDT 5A 115/230V AC
- **Logic output**
18VDC at 20mA
Min. Load: 400Ω
- **Communication**
RS442/RS485, 2 or 4-wire
Speed: 2.4K or 9.6K baud rate.
Protocol: MODBUS RTU slave

Analog Inputs

Single universal process input.

- **Type**
Universally Configurable for:
Thermocouple (THC)
Resistance Thermometer (RTD)
Millivolt
Current
DC voltage
- **Input impedance:**
mA >100Ω
mV, V >10MKΩ

Physical

- **Size**
96mm (3.78 in.) x 48mm (1.89 in.)
x 125mm (4.92 in.) (Depth behind panel)
- **Weight**

250g (0.5lbs.) approx.

Electrical

- **Voltage:**
85 to 265 V AC 50/60 Hz
24VDC (option)
- **Power consumption:**
<6VA

5.2 ABB C150 DESCRIPTION

The C150 Universal Process Indicator is a highly versatile, 6-digit industrial display indicator, with the capability to measure and indicate temperature, pressure, flow, level and other process variables. The standard C150 provides a retransmission output and alarm relay. Further relay outputs and RS485 communications may be added to suit your applications.



5.3

ELECTRICAL CONNECTIONS

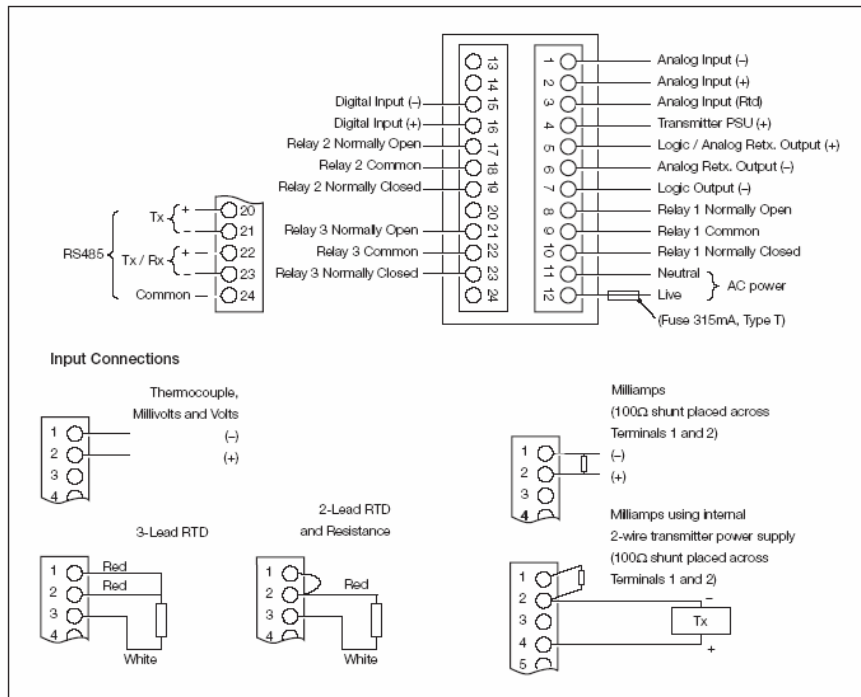

6. ABB 695FI REMOTE DISPLAY

Solid AT has tested the ABB 695FI000002113E remote display and found it to be the ideal solution for cases when an outdoor protected indicator is needed. Also having a HART communication protocol this remote display provides the ability to connect the 2-wire device to a PLC via HART communication Protocol.

6.1 ABB 695FI REMOTE DISPLAY SPECIFICATIONS

Operation

- **Display**
High intensity, 7-segment, 1 x 5 LCD display
Size 7mm
10 segments bar graph
- **Configuration**
User defined via front panel and internal links.

Outputs

- **Communication**
Hart Communication.

Analog Inputs

Single universal process input.

- **Type**

Current 4-20mA

Physical

- **Weight**

Depends on the selected approval.

6.2 ABB 695FI DESCRIPTION

Model 695FI field indicator provides simple and low cost remote indication of a process variable on an easy to read meter, ensuring the most useful display for any specific application. Traditional analog indicator is available with standard 0-100% linear or 0-10 square root graduations or special scales to be specified. This kind of display is also available with HART configuration capabilities (CoMeter).



6.3 ELECTRICAL CONNECTIONS

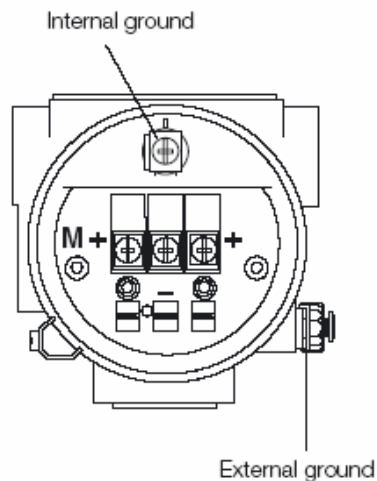

7. SHIMADEN SD16

Solid AT has tested the Shimaden SD16 remote display and found it to be the most cost effective solution for plants that only need the ability to monitor a process.

7.1 SHIMADEN REMOTE DISPLAY SPECIFICATIONS

Operation

- **Display**
Process value (PV) 7 segment Red LED 4 digits
Size 20mm (0.78 in.)
- **Configuration**
User defined via front panel and internal links.

Outputs

- **Analog output (option)**
0~10V DC (output resistance: 10 Ω).
0~10V DC (load current: 1mA max).
4~20mA DC (load resistance: 300 Ω max).

Analog Inputs

Single universal process input.

- **Type**
Universally Configurable for:
Thermocouple (THC)
Resistance Thermometer (RTD)
Linear Millivolt
Linear Current
Linear DC voltage
- **Input Sampling Rate**
1 sample/500ms
- **Input impedance:**
Millivolts/THC/RTD >500K Ω
Current <250 Ω

Physical

- **Size**
48mm (1.89 in.) x 96mm (3.78 in.)
x 110mm (4.33 in.) (Depth behind panel)
- **Weight**
~250g (0.44lbs.) approx.

Electrical

- **Voltage:**
100 to 240 V AC 50/60 Hz
24V DC (option)
- **Power consumption:**
11VA (AC) max. 7W (DC) max.

7.2 SHIMADEN SD16 DESCRIPTION

The SD16 Controller unit is a compact single loop controller, with the capability to measure, indicate and control a variety of process variables. The unit is ideal for simple PID control, offering On/Off or time proportioning control with a one shot self-tune facility. The SD16 can also act as a communication slave device supporting RS232\485 physical layer behaving as an analog to a digital data converter.

The unit is quickly set up for most process signal inputs and, with IP66 (NEMA4) front panel protection, is suitable for a wide range of applications.



7.3 ELECTRICAL CONNECTIONS

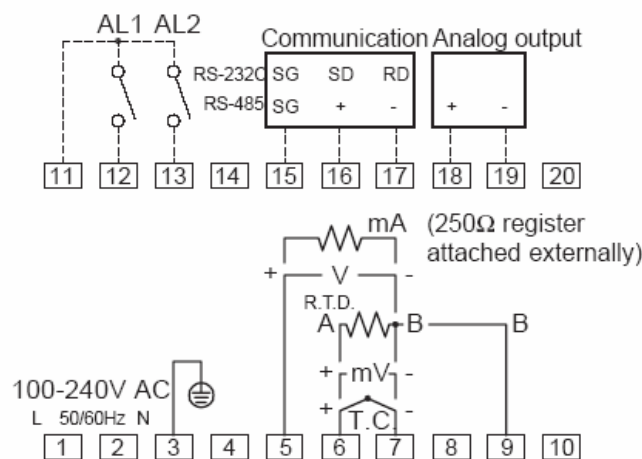

Please contact Solid AT's technical support team whenever in doubt of which remote display device is most suitable.